

## Guide

Débuter avec 1 module Audio  
2 modules Audio connectés  
1 module MIDI  
3 modules MIDI connectés  
1 module MIDI & 1 module Audio  
Echantillonneur MIDI avec SoundFont  
Enregistrement Audio  
Enregistrer MIDI  
Plugin VST  
Plugin VSTi  
Allumer / Eteindre  
12 Préréglages  
Contrôleur MIDI  
Symboles, Abréviations  
ARGO -> GarageBand  
Reaktor -> ARGO  
ARGO -> Ableton Live  
Ableton Live -> ARGO  
ARGO Appli FluidSynth

## Tutorial

Begin with 1 Audio module  
2 connected Audio modules  
1 MIDI module  
3 connected MIDI modules  
1 MIDI module & 1 Audio module  
SoundFont MIDI Sampler  
Audio recording  
MIDI recording  
VST plugin  
VSTi plugin  
On/Off  
12 Presets  
MIDI Controller  
Symbols, Abbreviations  
ARGO -> GarageBand  
Reaktor -> ARGO  
ARGO -> Ableton Live  
Ableton Live -> ARGO  
ARGO Appli FluidSynth

ARGO Audio enregistré par  
GarageBand 🎸  
grâce à SoundFlower 🌸

ARGO Audio recorded on  
GarageBand 🎸  
thanks to SoundFlower 🌸

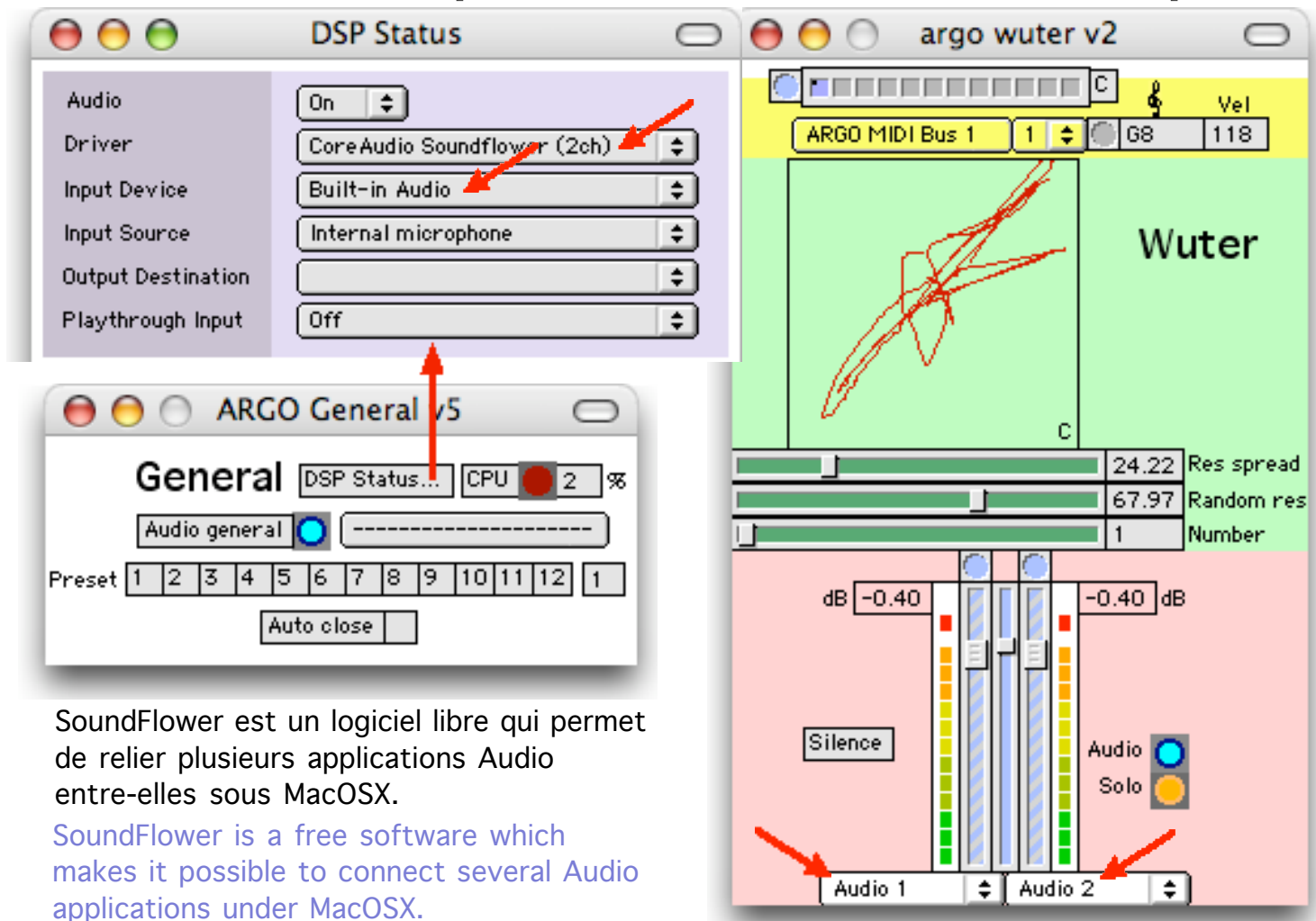



SoundFlower est un logiciel libre qui permet de relier plusieurs applications Audio entre-elles sous MacOSX.

SoundFlower is a free software which makes it possible to connect several Audio applications under MacOSX.

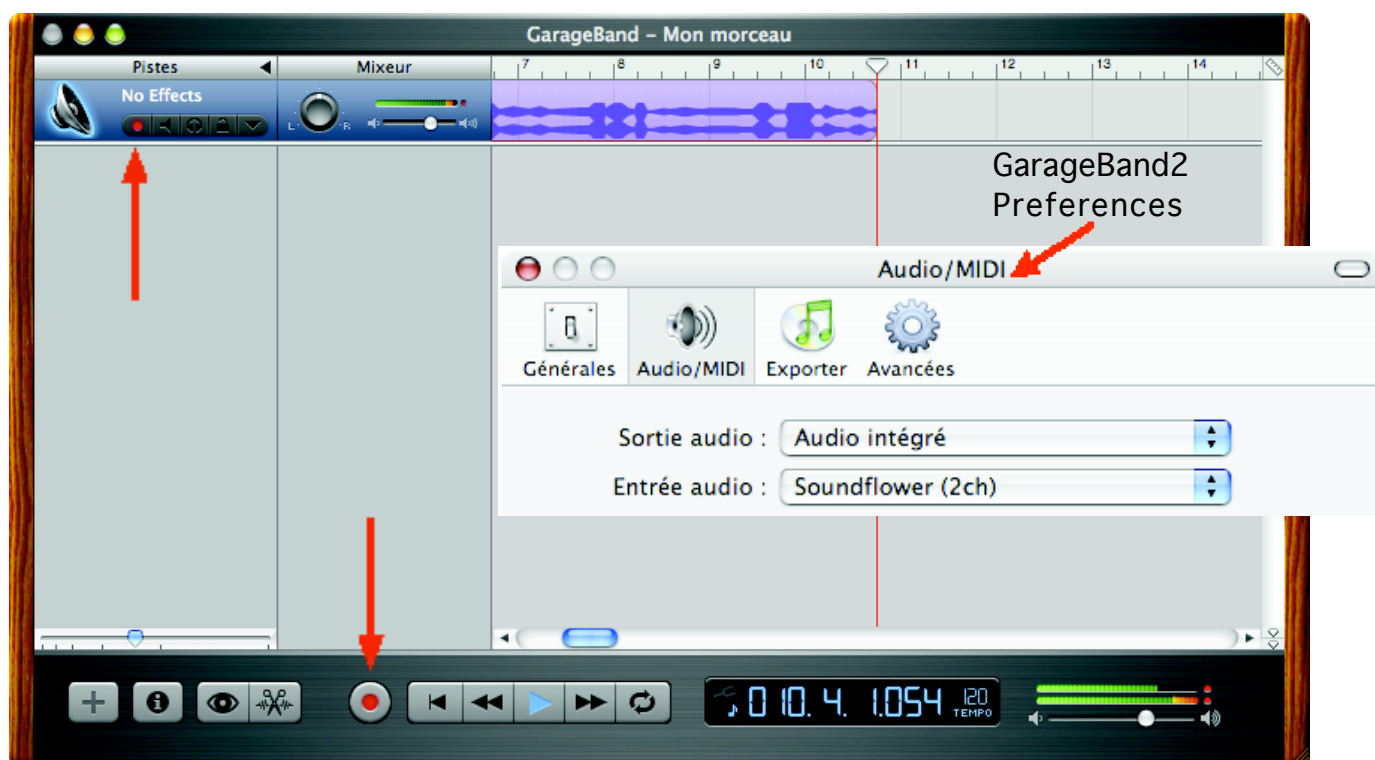
<http://www.cycling74.com/products/soundflower.html>



Reaktor  -> SoundFlower  -> ARGO Audio (MacOSX)  
 (Native Instruments)

Le son de Reaktor est entendu, transformé et enregistré à travers les modules ARGO grâce à SoundFlower



Reaktor sound is heard, transformed, and recorded through ARGO modules thanks to SoundFlower

Reaktor -> Menu System ->  
 -> Audio + MIDI settings... ->

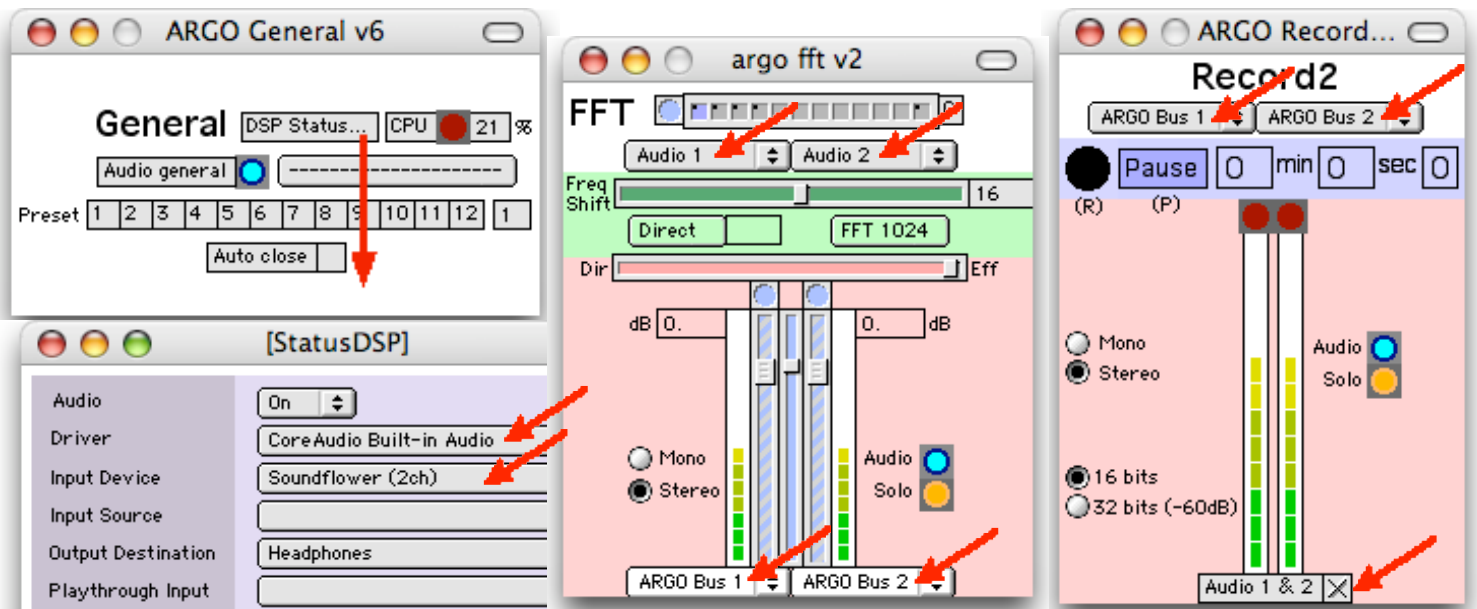
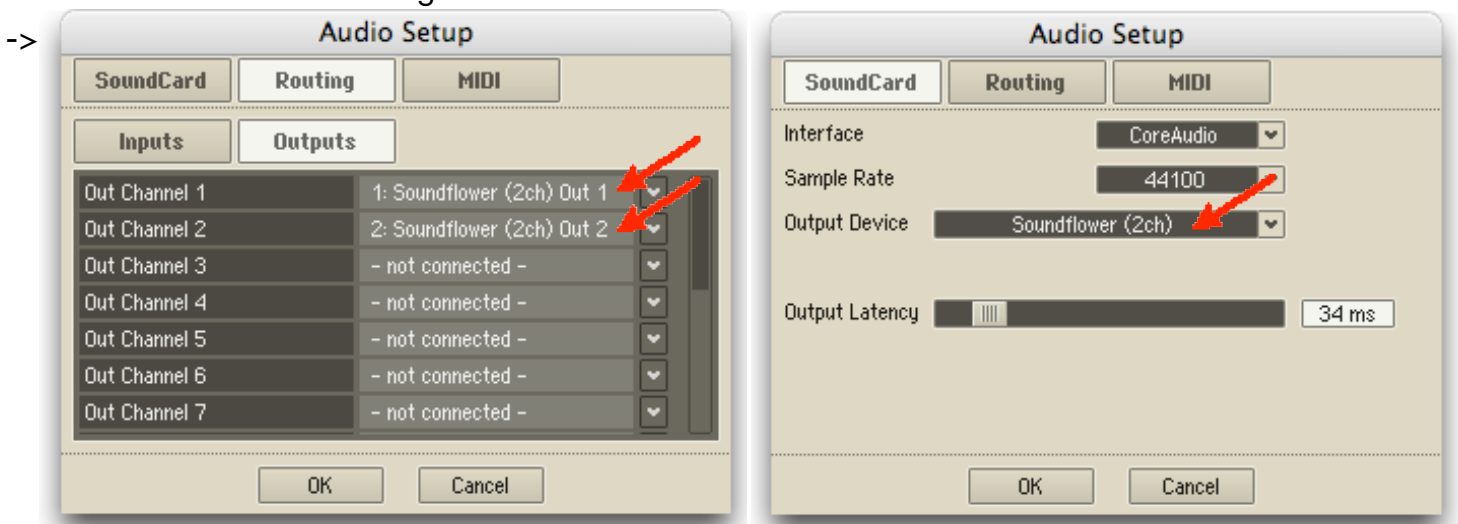

Reaktor 5 Demo -> <http://www.native-instruments.com/>

## Ex

Ouvrir les 4 modules ARGO. Ne pas ouvrir le fichier audio "Boris4.aiff". Des modules ARGO l'ouvriront automatiquement...

Open the 4 ARGO modules. Don't open "Boris4.aiff" audio file. ARGO modules will open automatically...

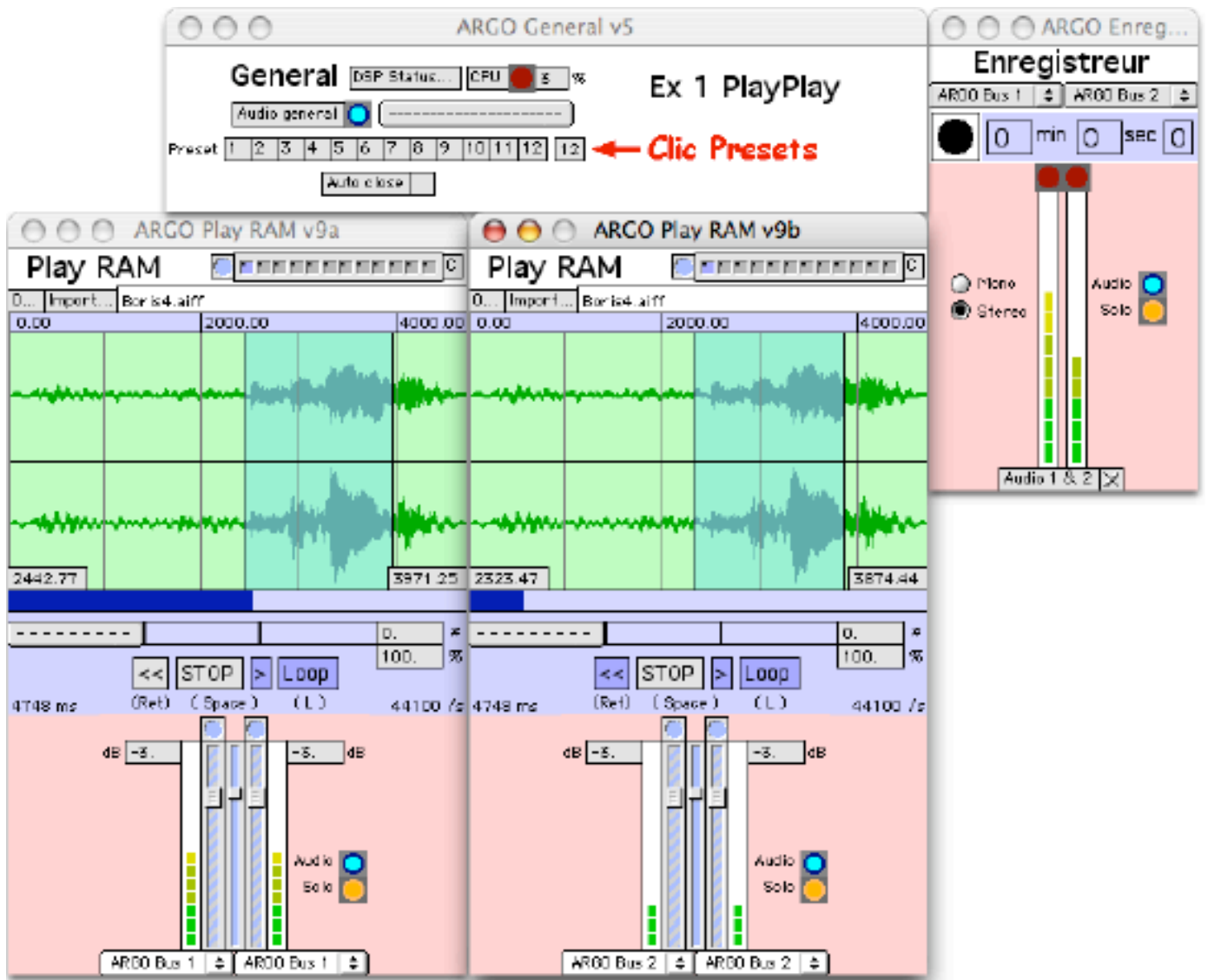

Jouer

Enregistrer le résultat sonore avec le module ARGO Enregistreur

Pour jouer: utiliser la souris ou le clavier

Play

Record the sound result with ARGO enregistreur module

To play, use mouse or keyboard

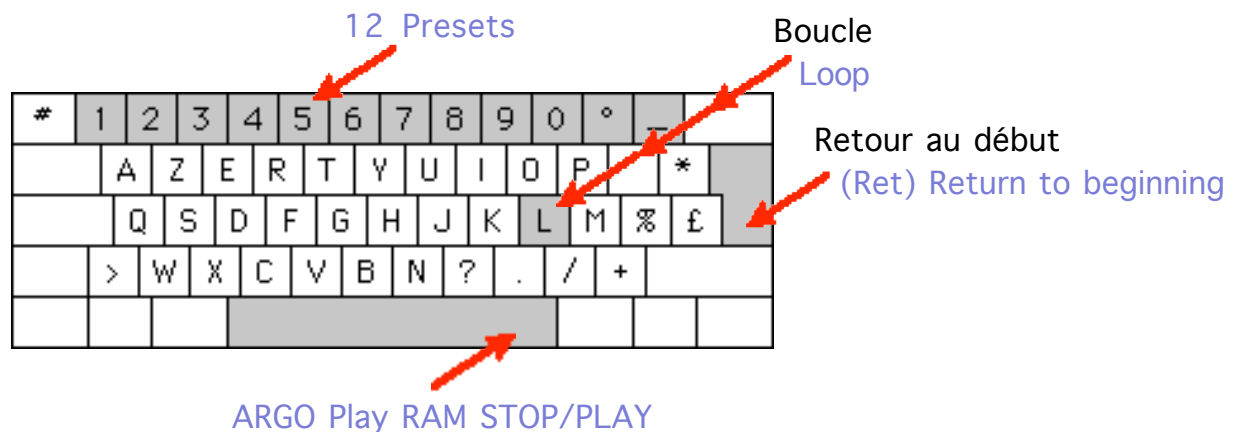

## Exemple, Exercice, Extrait...

Le mieux, pour apprendre l'usage de ARGO est d'ouvrir les "Ex".

Ils sont à télécharger 1 par 1 depuis le site web.

<a href="#">Ex1...</a>	<b>PlayPlay</b>	🔊 mp3
<a href="#">Ex6...</a>	<b>Miroir Mirror</b>	🔊 mp3
<a href="#">Ex19...</a>	<b>VST mda</b>	🔊 mp3
<a href="#">Ex32...</a>	<b>Sample &amp; hold</b>	🔊 mp3
<a href="#">Ex54...</a>	<b>Liquid Solid</b>	🔊 mp3
<a href="#">Ex56...</a>	<b>Verre Glass</b>	🔊 mp3
<a href="#">Ex59...</a>	<b>FormAlea tablet</b>	🔊 mp3
<a href="#">Ex61...</a>	<b>MIDI Trumpet</b>	🔊 mp3
<a href="#">Ex72...</a>	<b>Baroque Fluid</b>	🔊 mp3
<a href="#">Ex73...</a>	<b>Clics</b>	🔊 mp3

Chaque Ex est accompagné d'un fichier mp3 d'environ 1 minute, qui permet de l'entendre en situation de jeu.

Un Ex est un dossier contenant plusieurs modules ARGO et parfois d'autres types de fichiers (Audio, MIDI...)

Exemple: Ex1 sous MacOS9 ou MacOSX

Télécharger "Ex1MacOS9X.sit"

Décompresser "Ex1MacOS9X.sit" avec Stuffit Expander

Stuffit Expander est installé avec Mac OS9 ou MacOSX.2 ou MacOSX.3

Stuffit Expander n'est pas installé avec MacOSX.4 Tiger. L'installer à partir de:

<http://www.stuffit.com/mac/expander/download3.html>

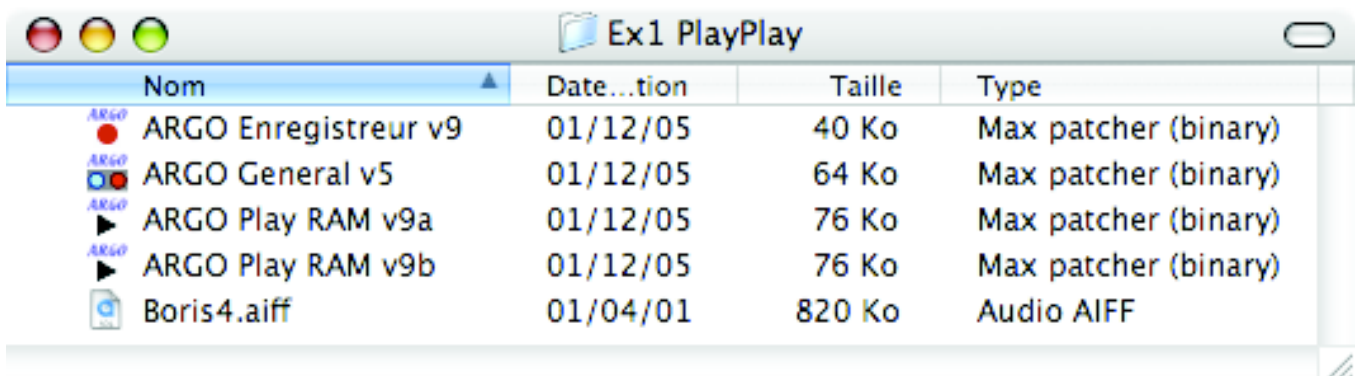

Nom	Date...tion	Taille	Type
ARGO Enregistreur v9	01/12/05	40 Ko	Max patcher (binary)
ARGO General v5	01/12/05	64 Ko	Max patcher (binary)
ARGO Play RAM v9a	01/12/05	76 Ko	Max patcher (binary)
ARGO Play RAM v9b	01/12/05	76 Ko	Max patcher (binary)
Boris4.aiff	01/04/01	820 Ko	Audio AIFF

Le dossier "Ex1 PlayPlay" contient 4 modules ARGO (de type "Max patcher") et 1 fichier audio au format AIFF

## Ex

The best thing to do, if you want to get used to ARGO is to open the "Ex".

Download the Ex one by one from the web site.

## Example, Exercise, Extract...

Each Ex is accompanied by a mp3 file of approximately 1 minute, which makes it possible to hear it in situation of play.

An Ex is a folder containing several ARGO modules and sometimes other types of files (Audio, MIDI...)

Example: Ex1 under MacOS9 or MacOSX

Download "Ex1MacOS9X.sit"

Decompress "Ex1MacOS9X.sit" with Stuffit Expander

Stuffit Expander is installed with Mac OS9 or MacOSX.2 or MacOSX.3

Stuffit Expander is not installed with MacOSX.4 Tiger. Install it from:

The "Ex1 PlayPlay" folder contains 4 ARGO modules (of type "Max patcher") and 1 audio file with AIFF format

# FluidSynth & SoundFont (MacOSX)

(Extrait de Ex72 Baroque Fluid)  
(Ex72 Baroque Fluid Extract)

Glisser un fichier MIDI au format O (1 piste) sur ARGO MIDI Play

Drag a format 0 (single track) MIDI file on ARGO MIDI Play



GolbergAriaFormat0.mid

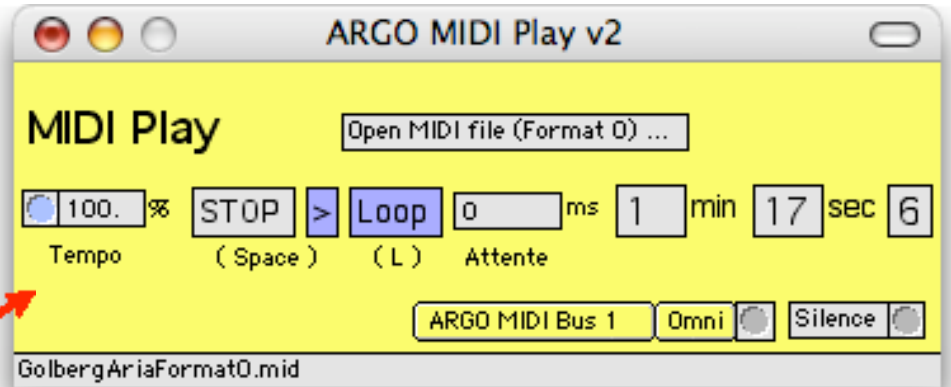

ARGO MIDI Play v2

Glisser une SoundFont sur ARGO FluidSynth

Drag a SoundFont on ARGO FluidSynth



Airfont 310.sf2

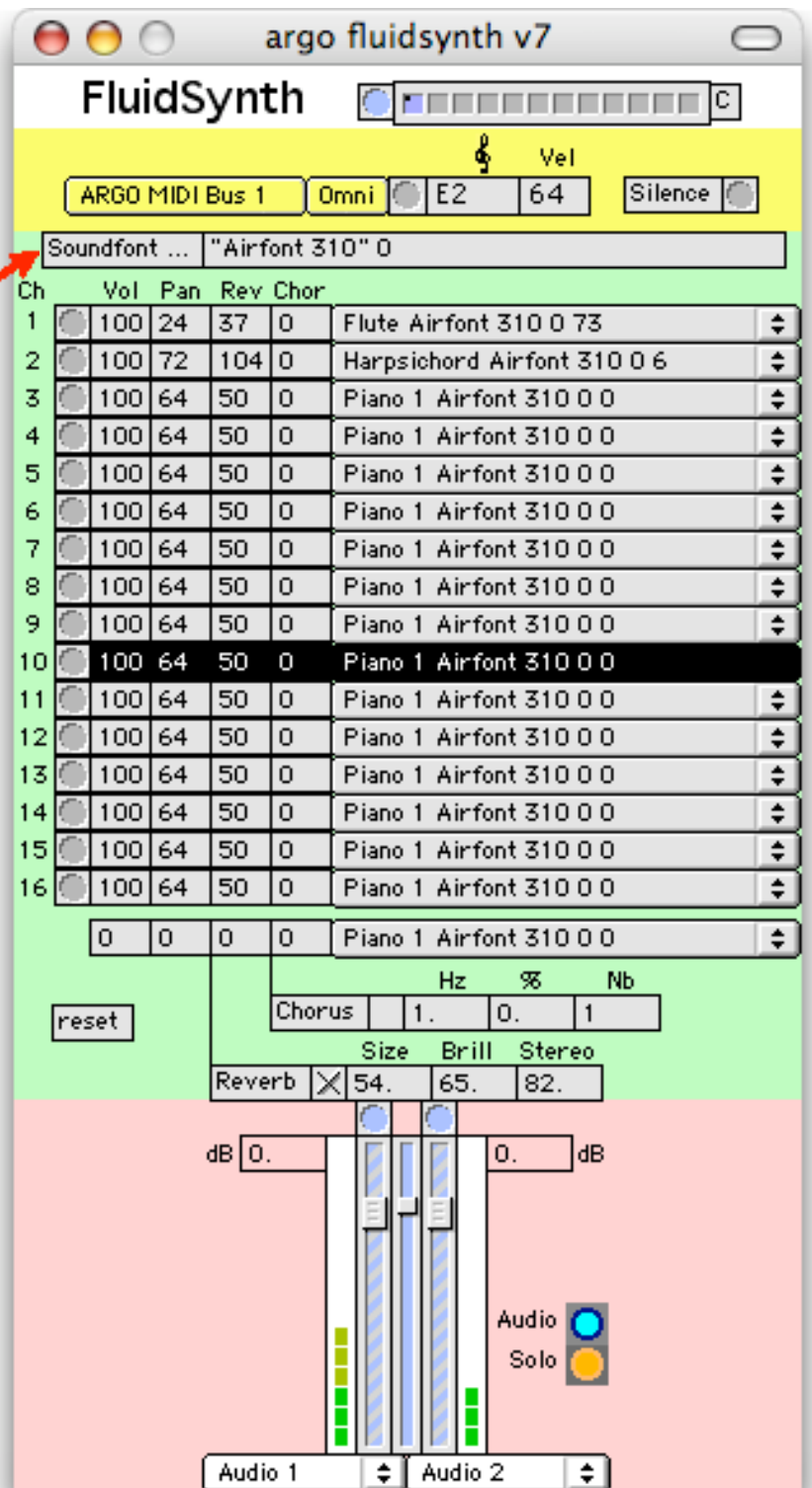

ARGO Fluidsynth v7 OSX

ARGO fluidSynth est un synthétiseur audio contrôlé par MIDI, pour MacOSX, utilisant des banques de sons au format "SoundFont 2"

ARGO fluidSynth is an audio synthesizer controlled by MIDI, for MacOSX, using soundbank with "SoundFont 2" format

ARGO MIDI Bus 1 relie les 2 modules  
ARGO MIDI Bus 1 links the 2 modules

Ex72 utilise la SoundFont "Airfont 310.sf2" de Milton Paredes  
Ex72 uses SoundFont "Airfont 310.sf2" of Milton Paredes  
<http://www.sf2midi.com/>

utilise un objet "fluidsynth~"  
FluidSynth is a sound font synthesizer written by Peter Hanappe et al.  
Max/MSP integration by Norbert Schnell with Roland Cahen

# ARGO Audio -> Rewire -> Ableton Live

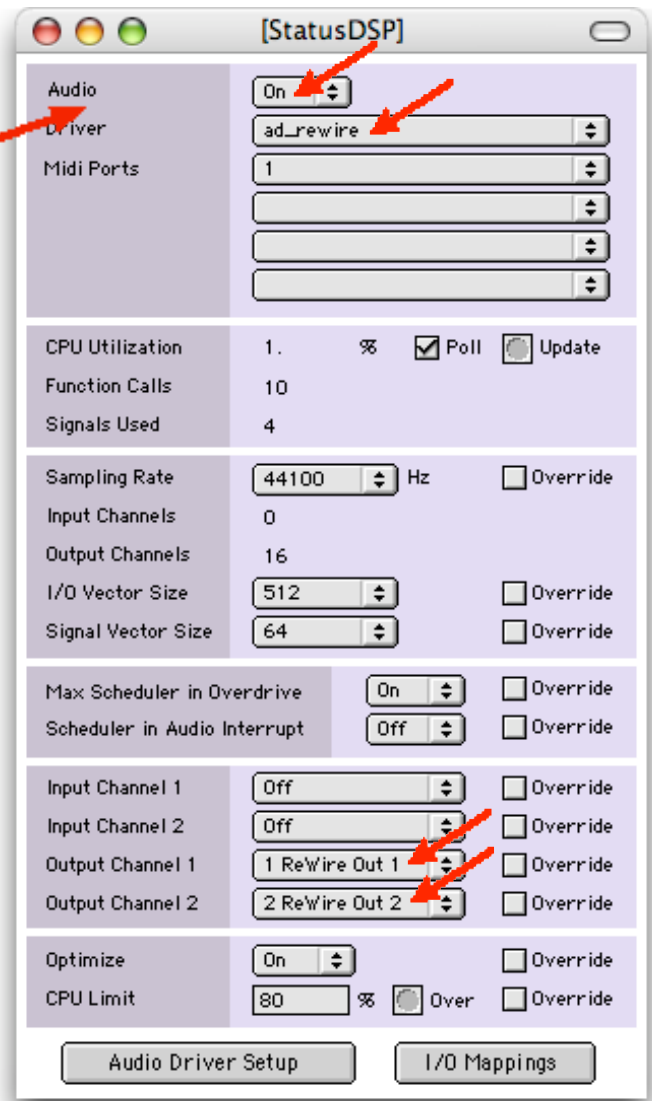
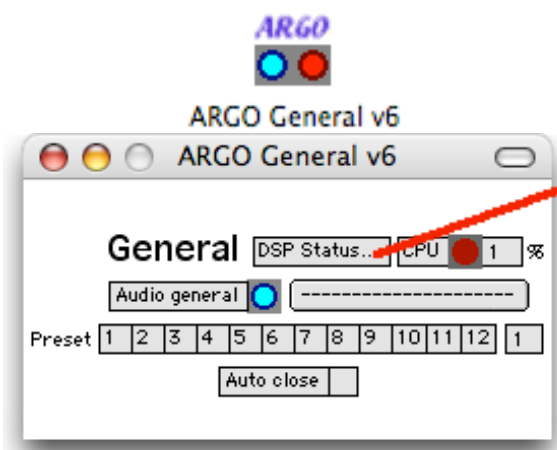

Enregistrement  
des sorties Audio  
1 & 2 des modules  
ARGO dans un clip  
Live 5

Lecture du  
clip dans  
Live 5

Recording of Audio  
Output 1 & 2 of  
ARGO modules in a  
Live 5 clip

Playing of  
the clip in  
Live 5



Live 5 -> Préférences...

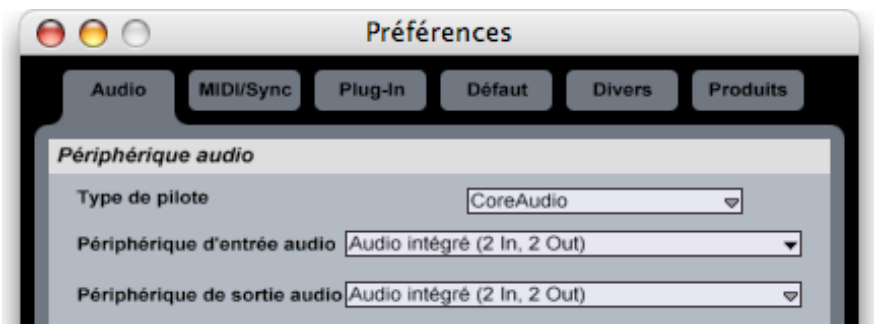

<http://www.ableton.com/pages/downloads/demo>

Testé sous MacOSX. Sous Windows ???  
Tested under MacOSX. Under Windows???

# Ableton Live -> SoundFlower -> ARGO Audio (MacOSX)

Le son de Live est entendu, transformé, enregistré à travers ARGO

Live sound is heard, transformed, recorded through ARGO

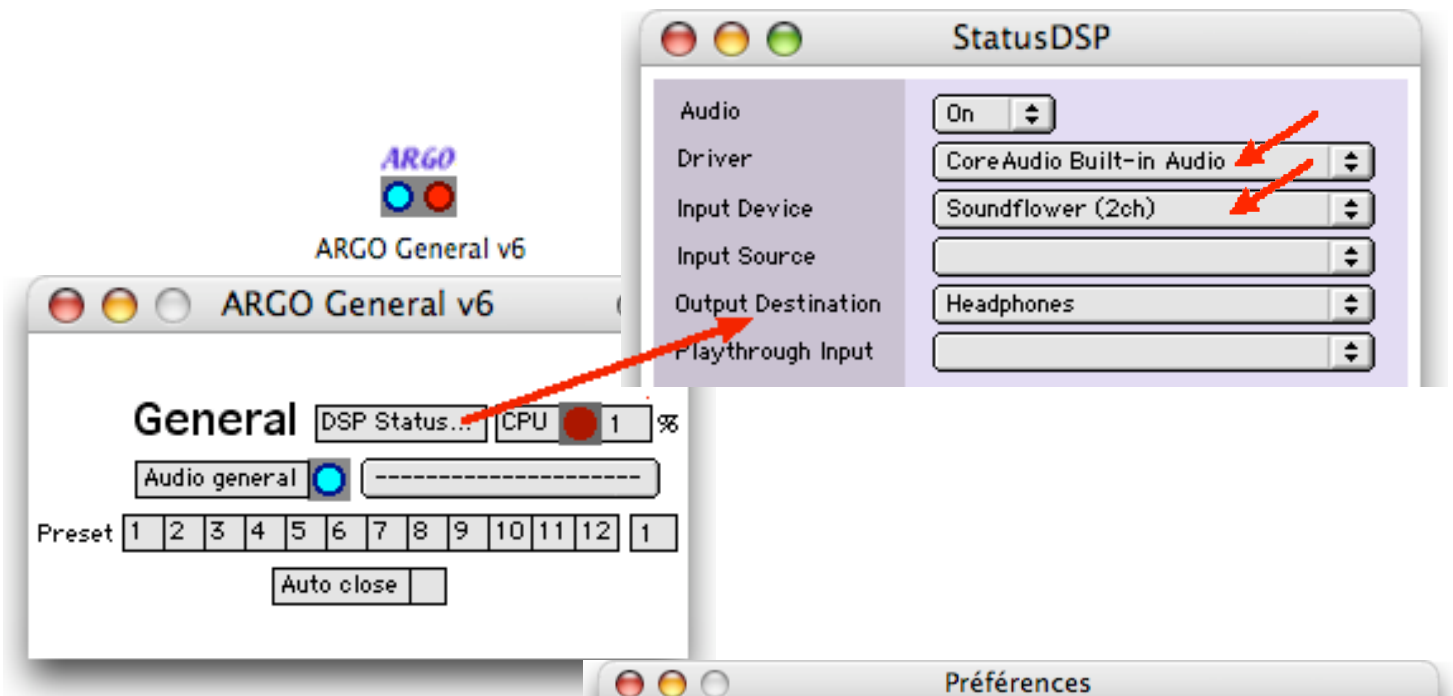

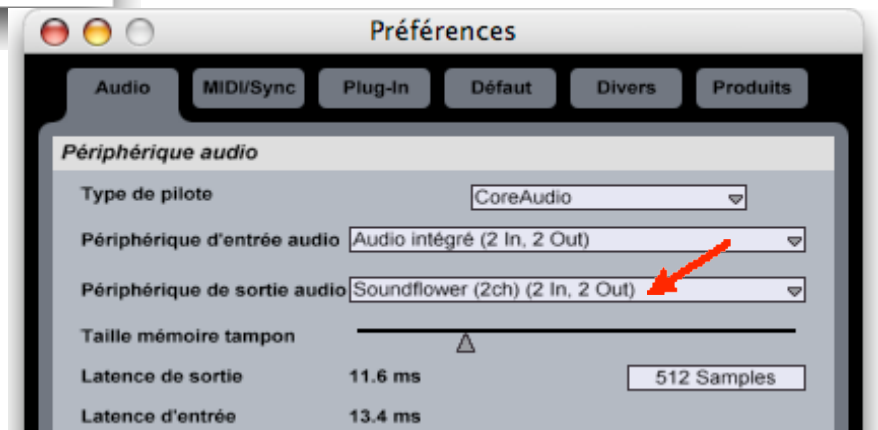

Live 5 -> Préférences...



Le son de Live est entendu à travers le module ARGO Record

Live sound is heard through module ARGO Record

Clic ->  ->  -> Enregistrement AIFF ou Wave  
-> Recordibg AIFF or Wave

D'autres modules ARGO peuvent être insérés pour transformer le son de Live

Other ARGO modules can be inserted to transform the Live sound

<http://www.ableton.com/pages/downloads/demo>

SoundFlower est un logiciel libre qui permet de relier plusieurs applications Audio entre-elles sous MacOSX

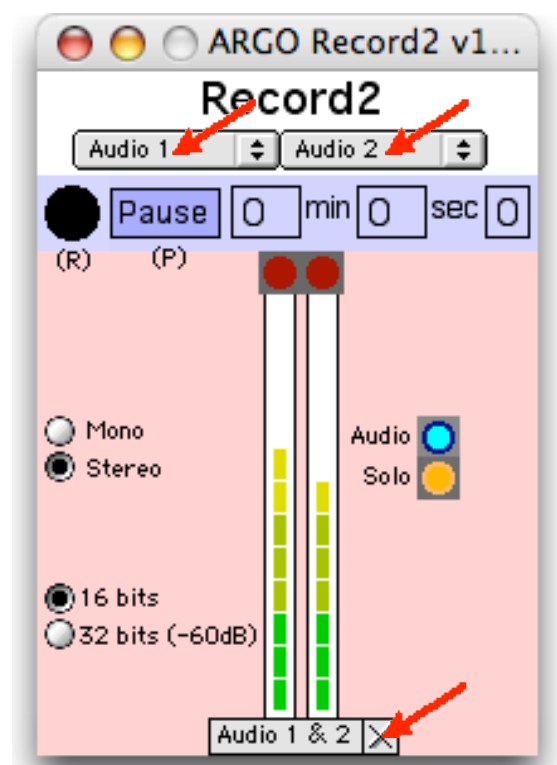

SoundFlower is a free software which makes it possible to connect several Audio applications under MacOSX

<http://www.cycling74.com/products/soundflower.html>





# Programmeurs Max/MSP



- ARGO est conçu pour des utilisateurs qui n'ont jamais programmé avec Max et MSP.
- Il faut pouvoir ouvrir plusieurs fois le même module, chacune de ces instances du même module étant indépendante des autres, donc:
  - send, send~, receive, receive~ sont souvent inutilisables.
  - un nom différent à chaque ouverture est donné aux buffer~. Ce nom est constitué du nombre de 'ticks' depuis l'allumage du Mac.
  - Les objets send~ et receive~ sont utilisés pour les 12 "ARGO Bus", pour le contrôle des presets... communs à tous les modules.
- Un module ARGO est un "Patch" ou un "Collective"
- Seuls les "Objects" standards (dossiers max-startup et externals) sont utilisés dans les patches
  - Il n'y a aucun objet à déposer quelque part.
  - Les modules utilisant un objet absent de l'installation standard sont construits sous forme d'un "Collective" avec une icône ->  au lieu de  (Fichier xxx.mxf au lieu de xxx.pat sous Windows)
- Seule la police de caractères 'Geneva' est utilisée.
- Pour éditer un module: • L'ouvrir et clic -> 

```
window flags grow,  
window exec
```
- Il faut pouvoir déplacer les modules dans n'importe quel dossier donc tous les bpatcher sont "Embed in Parent Patcher."
- Musiciens et acousticiens apprécient la double notation des hauteurs -> 

A3	440.
----	------

 Hz
- La conception modulaire interdit une version "standalone": il faudrait créer une application par module (de plus le même module doit pouvoir être ouvert plusieurs fois).
- Fait avec MaxMSP 4.1 sous MacOS9, MaxMSP 4.5.7 sous MacOSX.3, MaxMSP 4.5.7 sous Windows XP pro
- Sur le site Web, "ARGOModuleModel.sit" pour MacOSX et "ARGOModuleModel.zip" pour Windows contiennent la méthode (1ARGOBusExplained.pat) pour relier un patch à un module ARGO en Audio ou MIDI et 2 modèles (2ARGOModuleModelSimple.pat et 3ARGOModuleModel.pat) pour rapidement fabriquer un module ARGO

## Maxers...

- ARGO is conceived for users who had never programmed with Max and MSP.
- It is necessary to be able to open several times the same module, each one of these instances of the same module being independent of the other, therefore:
  - send, send~, receive, receive~ are often unusable.
  - a different name with each opening is given to the buffer~. This name is the number of ' ticks' since the startup of the computer.
  - the send~ and receive~ objects are used for the 12 "ARGO Bus", for the control of the presets... common to all the modules.
- An ARGO module is a patch or a collective
- Only the standard "Objects" (in folders max-startup and externals) are used in the patches
  - There is no object to deposit somewhere
  - The modules using an object missing of the standard installation are built as collective with an icon ->  instead of  (xxx.mxf instead of xxx.pat file under Windows)
- The only the font used is ' Geneva'.
- To edit a module: open it and click -> 

```
window flags grow,  
window exec
```
- It is necessary to be able to move the modules in any folder, thus, all the bpatcher are "Embed in Parent Patcher."
- Musicians and acousticians appreciate the double pitch notation -> 

A3	440.
----	------

 Hz
- Modular concept prohibited a "standalone" version: it would be necessary to create an application by module (moreover the same module must be able to be open several times).
- Build with MaxMSP 4.1 under MacOS9, MaxMSP 4.5.7 under MacOSX.3, MaxMSP 4.5.7 under Windows XP pro
- On the Web site, "ARGOModuleModel.sit" for MacOSX and "ARGOModuleModel.zip" for Windows contain the method (1ARGOBusExplained.pat) to connect a patch to an ARGO module in Audio or MIDI and 2 models (2ARGOModuleModelSimple.pat and 3ARGOModuleModel.pat) for quickly build an ARGO module

Nom	Type
1ARGOBusExplained.pat	Max patcher (binary)
2ARGOModuleModelSimple.pat	Max patcher (binary)
3ARGOModuleModel.pat	Max patcher (binary)
bpatch Entree Audio Mono 9.pat	Max patcher (binary)
bpatch Entree MIDI tout v8.pat	Max patcher (binary)
bpatch Sortie Audio Ster 18dB14.pat	Max patcher (binary)

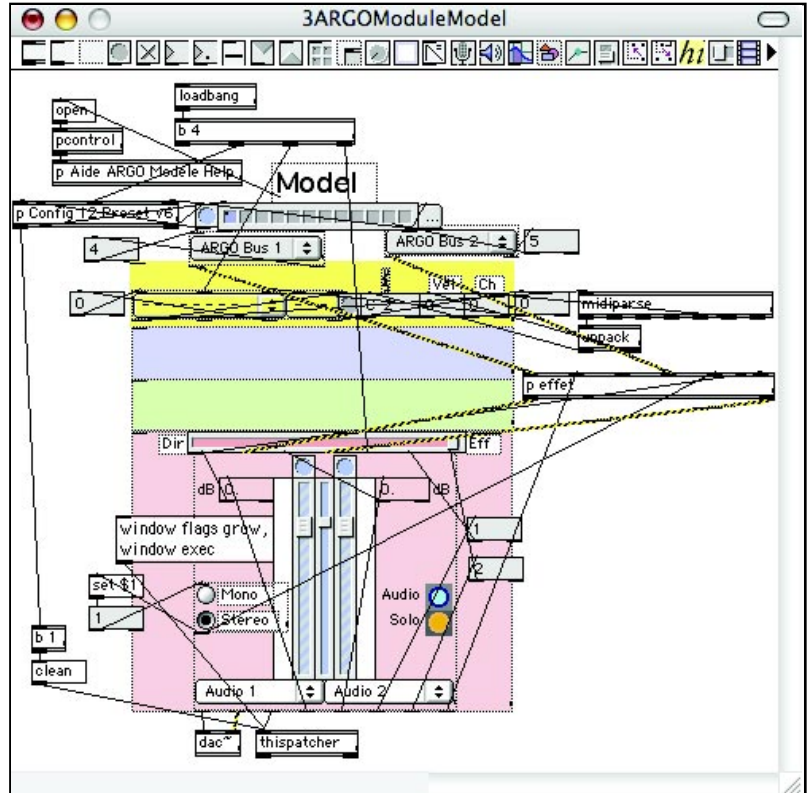
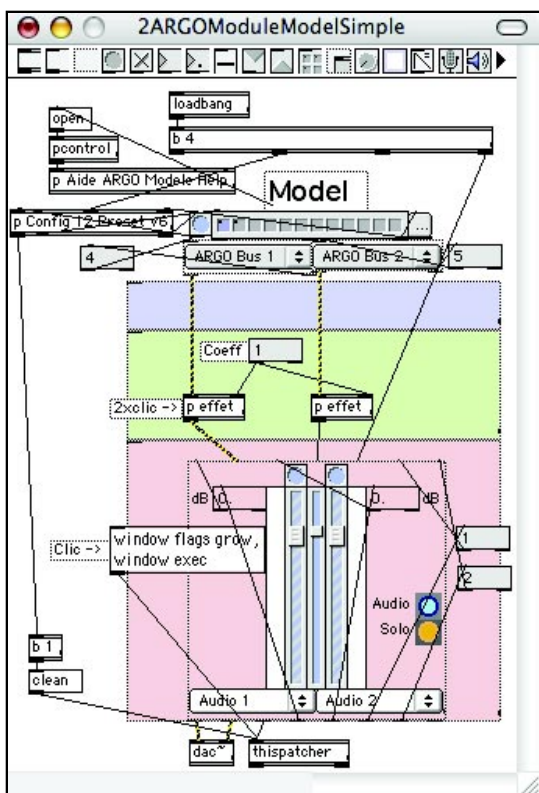
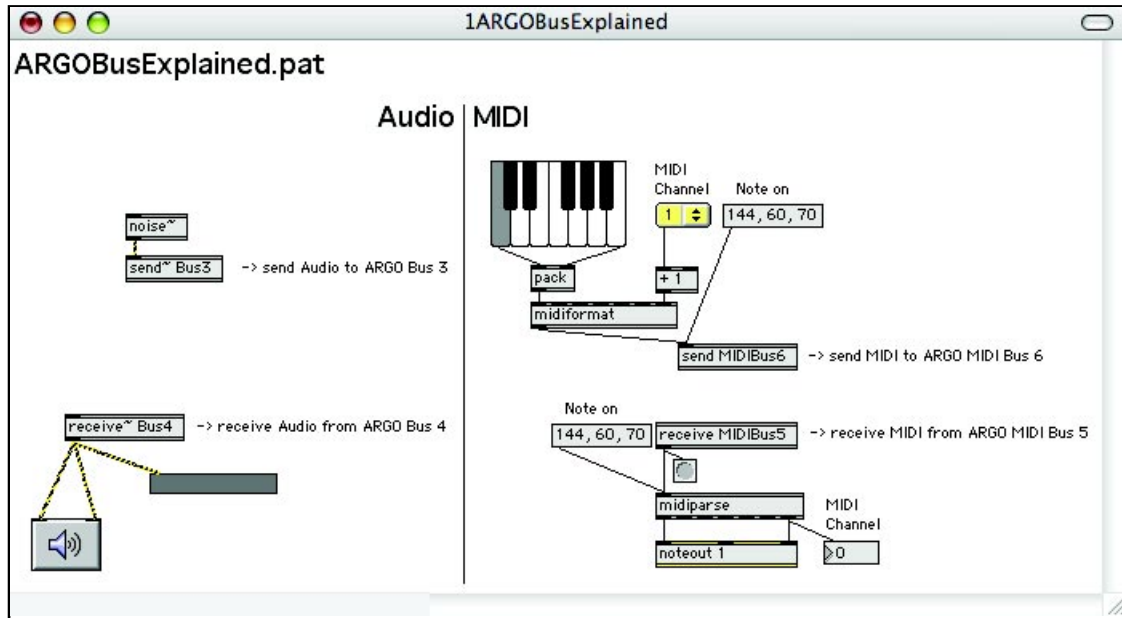

# Reason (Propellerhead Software) -> Rewire -> ARGO Audio

Le son de Reason est entendu, transformé, enregistré à travers ARGO

Reason sound is heard, transformed, recorded through ARGO

"MSP acts as a ReWire mixer"

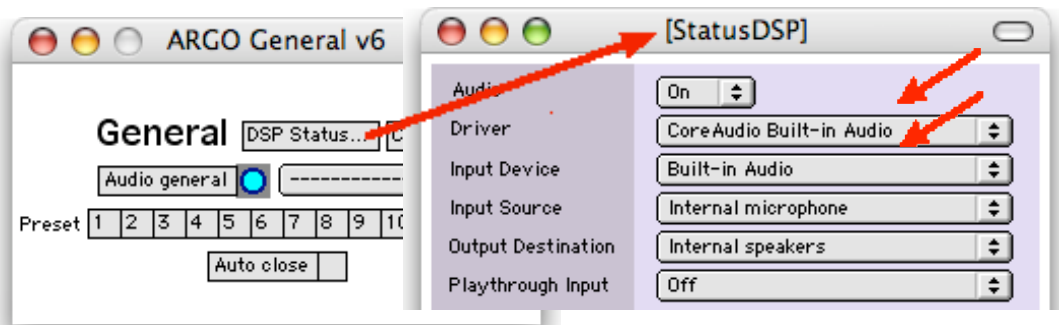

ARGO Del est un exemple. D'autres modules ARGO peuvent être insérés pour transformer le son de Reason

- 1 Lancer Max/MSP [Launch](#)
- 2 Ouvrir ARGO Rewire [Open](#)
- 3 Executer [Execute](#)
- 4 Lancer Reason [Launch](#)

ARGO Del is an example. Other ARGO modules can be inserted to transform the Reason sound

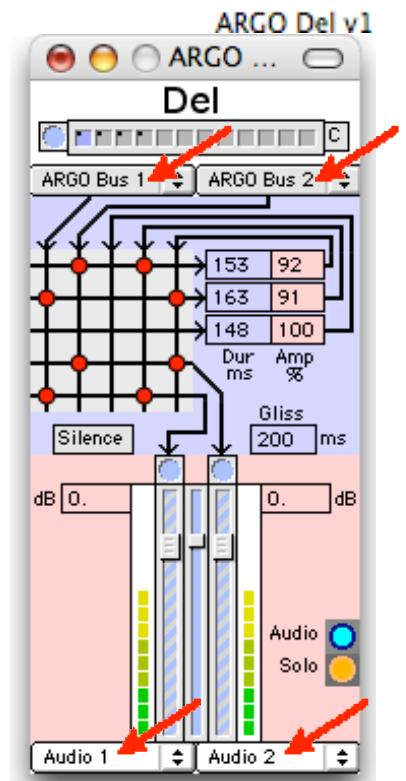
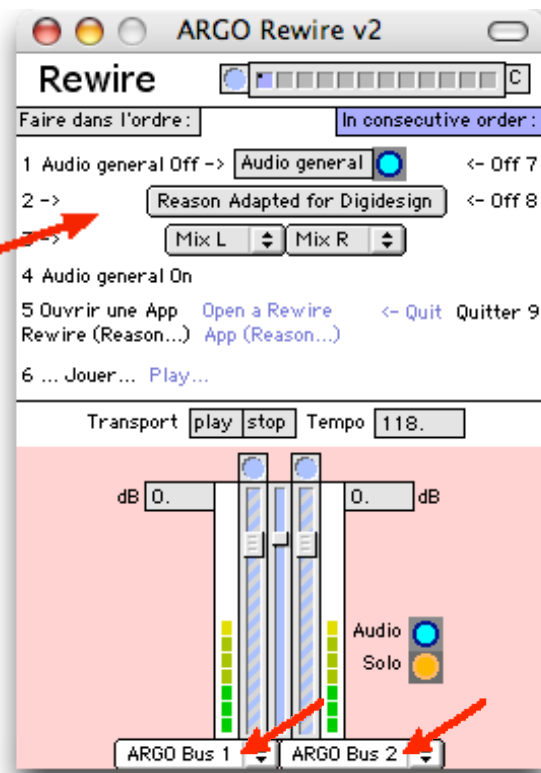

Reason 2.5 -> Preferences...



NN19 par exemple [by example](#)

